

Labeling and Argument Doubling in Japanese*

Saito Mamoru**

Center for Linguistics

Nanzan University

ABSTRACT

Chomsky's (2013) labeling algorithm plays a fundamental role in the pursuit of minimalist syntax, restricting the structures that free Merge generates. I suggest that it also explains the effects of the θ -criterion to the extent that they are correct. This leads to the conclusion that the θ -criterion, as it is currently formulated, should be dispensed with. I first note that the θ -criterion and the labeling algorithm overlap in their effects in English. Then, I introduce the labeling mechanism for Japanese that I argued for in Saito (2014). It assumes that the language lacks ϕ -feature agreement altogether and claims that suffixal Case serves to aid labeling. With this background, I discuss examples of argument doubling from Kuroda (1988), where a verb assigns a single θ -role to two distinct arguments. I show that these and other similar examples are successful with labeling but violate the θ -criterion. Their grammaticality demonstrates then that the θ -criterion should be eliminated in favor of labeling. At the end, I examine the conditions on argument doubling and suggest that one of the doubled arguments must be construed as a focus and the other must serve to specify the set of alternatives for the focus in the sense of Rooth (1992). Based on this, I speculate that though the θ -criterion is untenable, Full Interpretation requires that each constituent play a unique role in the semantics.

Key words: argument doubling, free Merge, labeling, the θ -criterion, focus, set of alternatives

* I am happy to be able to contribute this paper to a volume in celebration of the 30th anniversary of the Tsing Hua Institute of Linguistics, which has been a leading center for linguistic research in Asia. The material in this paper was presented in a syntax seminar at the University of Connecticut (March 2016) and at the Geneva workshop on clausal and nominal complements in monolingual and bilingual grammars (June 2016). I thank the participants for helpful comments.

** Author's email address: saito@nanzan-u.ac.jp

1. Introduction

Chomsky's (2013) labeling algorithm aims to explain, among other things, why internal merge is restricted the way it is and why language includes ϕ -feature agreement. In this paper, I suggest that it explains, in addition, the effects of the θ -criterion to a large extent. If the suggestion is correct, the θ -criterion, as it is currently formulated, should be dispensed with. The argument is based on the analysis of Japanese, a language that lacks ϕ -feature agreement.

In the following section, I briefly go over Chomsky's (2013) labeling algorithm and the analysis of Japanese in Saito (2014). There, I note that the former excludes typical cases of θ -criterion violations in English whereas the latter predicts that Japanese allows argument doubling in the absence of the θ -criterion. Then, in Section 3, I examine Japanese examples in violation of the θ -criterion. I first consider examples with multiple themes, originally observed by Kuroda (1988), and then show that argument doubling is a general phenomenon in the language, presenting examples with multiple external arguments and multiple source and goal PPs. Section 4 contains a preliminary discussion on the restrictions on argument doubling. I suggest that two arguments with the same thematic role must contribute to the semantic form in distinct ways. In the cases taken up, one is interpreted as focus and the other specifies the set of alternatives for the focus in the sense of Rooth (1992).

2. Labeling in Japanese

The minimal operation, Merge, applies to two objects α and β , and forms a new object $\gamma = \{\alpha, \beta\}$. Chomsky (2013) hypothesizes that it must accompany an algorithm to determine the nature (or label) of the newly formed object. When a verb and a nominal element are merged, the interpretation requires information on whether the formed object is verbal (VP) or nominal (DP), for example. He considers the three cases listed in (1).

- (1) a. $\gamma = \{H, \alpha P\}$
 b. $\gamma = \{\alpha P, \beta P\}$
 c. $\gamma = \{H_1, H_2\}$

(1a) is straightforward as search into γ immediately yields a unique head, H. In this case, it can be assumed that H determines the label of γ . On the other hand, (1b)-(1c) are problematic because the label of γ cannot be determined straightforwardly.

Given this, Chomsky makes two concrete proposals to accommodate instances of (1b) that arise in actual derivations. Let us consider the structure in (2).

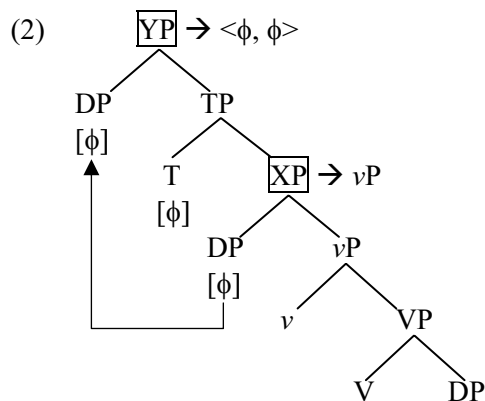

Merge applies first to yield $\{V, DP\}$ and then $\{v, \{V, DP\}\}$. These cases are instances of the unproblematic (1a). But then, the configuration in (1b) arises when the subject DP and vP merge. In this case, the DP internally merges with TP later in the derivation after T is introduced into the structure. Chomsky proposes that vP determines the label of XP at this point because it is the unique element that XP properly contains. The internal merge of DP with TP again creates an instance of (1b). Here, the DP and (the label of) TP share the same ϕ -features due to ϕ -feature agreement. Chomsky suggests that this feature sharing makes it possible to label YP as $\langle \phi, \phi \rangle$.

Chomsky (2013) points out that this analysis extends to structures created by wh-movement. Let us consider (3):¹

¹ The movement proceeds through the edges of vP as well. I ignore this for ease of exposition.

- (3) [YP Which book [CP do [TP you think [XP [CP that [TP John bought _]]]]]]
-

There are two instances of internal merge of a wh-phrase with a CP. In the embedded clause, a wh-phrase merges with a non-question CP. This is allowed because the wh-phrase moves further, and as a result, CP provides the label of XP as the only element properly contained within XP. The one in the matrix is legitimate as the C heads a question with the feature Q, and the formed object (YP) can be labeled as $\langle Q, Q \rangle$ with feature sharing.

This analysis predicts that internal merge always terminates in a configuration of feature sharing. This is illustrated below.

- (4) a. Operator movement

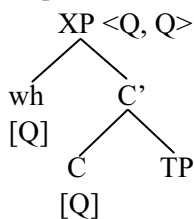

- b. NP-movement

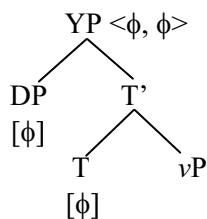

In particular, it excludes internal merge at TP and CP without feature sharing unless the merged phrase “moves on”. Then, internal merge, as an instance of Merge, is free but is severely restricted by the labeling algorithm. The “last resort” nature of internal merge is thus captured.

Chomsky’s (2013) proposals on labeling raise interesting research questions with languages like Japanese. First, Japanese lacks ϕ -feature agreement altogether, at least on the surface. So, it is not obvious how sentences are labeled. Secondly, it is well known that the language allows sentences with multiple nominative subjects. The following example is from Kuno (1973).²

² When the matrix predicate is individual-level, the sentence-initial nominative phrase is interpreted as the focus, as shown in the translation of (5). This holds also for the subsequent examples although I do not always indicate this in the translations. See Kuno (1973) and Heycock (2008) for detailed discussion on this interpretive property of matrix sentences with individual-level predicates.

- (5) [_{TP} Bunmeikoku-ga [_{TP} dansei-ga [_{TP} heikin-zyumyoo-ga mizika-i]]]
 civilized.country-NOM male-NOM average-life.span-NOM short-Pres.
 ‘It is in civilized countries that the male population has a short life-span.’

This is ruled out straightforwardly in English. As illustrated in (6), the merger of the higher subject results in failure of labeling because only the lower thematic subject shares ϕ -features with T.

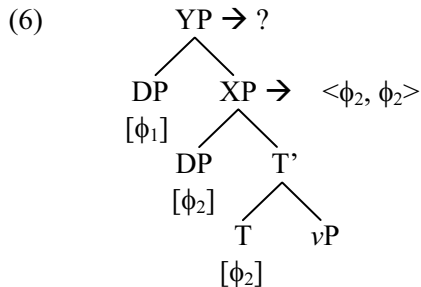

But then, why is (5) grammatical in Japanese?

Finally, Japanese has scrambling, which is argued to be neither operator movement nor A-movement. (7b) is a typical example.

- (7) a. Minna-ga [_{CP} Hanako-ga dono hon-o eran-da ka]
 all-NOM Hanako-NOM which book-ACC choose-Past Q
 sir-ita-gat-te i-ru
 want.to.know-Pres.
 ‘Everyone wants to know which book Hanako chose.’
- b. Dono hon-o minna-ga [_{CP} Hanako-ga _ eran-da ka] sir-ita-gat-te i-ru

A wh-question is embedded in (7a). In (7b), the wh-phrase, *dono hon-o* ‘which book-ACC’, is scrambled out of the embedded CP, where it takes scope. Yet, the example is perfectly grammatical and is interpreted exactly as (7a) without scrambling. The movement cannot be A-movement because it is clearly in violation of the locality imposed on A-movement. It cannot be operator movement either because if it were, the

scrambled phrase should take scope at the final landing site.³ Again, scrambling is ruled out in English, for example, by the labeling requirement. If a non-operator object is internally merged with CP or TP, then the formed object fails to be labeled as shown in (8).

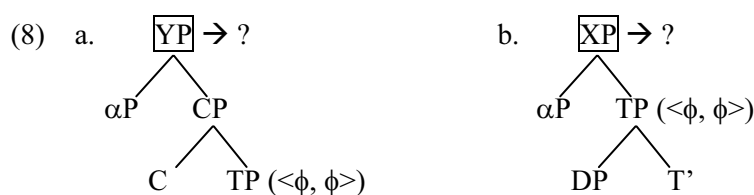

The characteristic properties of Japanese illustrated above suggest that the language employs a labeling mechanism that is not observed in languages with ϕ -feature agreement. The purpose of Saito (2014) was to look into this mechanism. The main part of the hypothesis presented there is that suffixal Case markers make phrases invisible for search and as a result, serve as anti-labeling devices. Let us consider (9) for a concrete illustration.

$$(9) \quad \gamma = \{\alpha P\text{-Case}, \beta P\}$$

The idea is that αP with Case is invisible when the label for γ is calculated, and hence, βP determines the label for γ .

This not only allows Japanese sentences to be labeled without ϕ -feature sharing but also accommodates examples with multiple nominative subjects, as shown in (10).

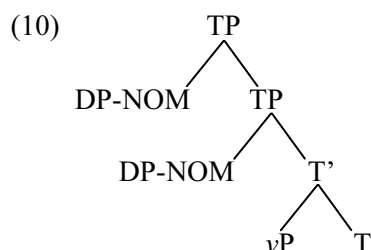

³ See Saito (1989, 2003) and Webelhuth (1989) for the non-operator, non-A nature of scrambling.

When the lower DP merges with T', T' determines the label of the formed object because the DP with suffixal Case is invisible. The same mechanism allows the merger of the higher DP, referred to as a 'major subject' in the literature. Since it accompanies suffixal Case, the lower TP determines the label of {DP-NOM, TP}. Thus, sentences with multiple nominative subjects are predicted to be grammatical.

The hypothesis also accounts for why scrambling is possible in Japanese. Scrambling in (11a) creates the configuration in (11b).

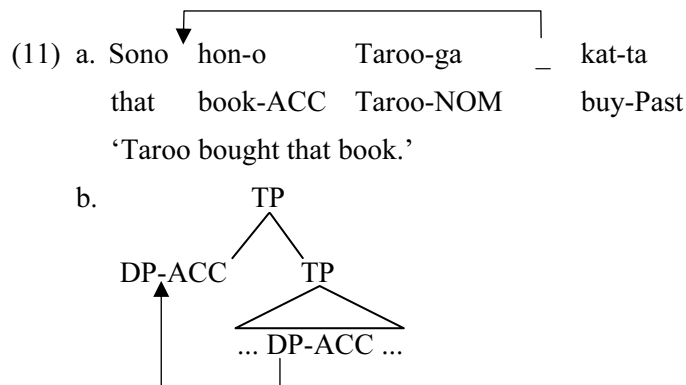

The object formed by this internal merge is successfully labeled. As DP-ACC is invisible for labeling, the lower TP provides the label for the newly formed TP.

The analysis for Japanese outlined above, if correct, makes it possible to examine the θ -criterion in an interesting way. Suppose, for example, that two theme objects appear in an English VP as in (12).

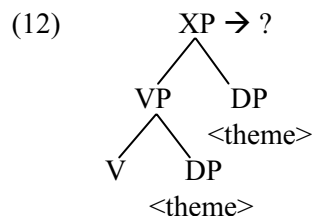

This structure has been ruled out by the θ -criterion as the verb assigns the theme role to two distinct DPs. However, note that labeling fails in this structure as well. When the VP

and the higher DP merge, the formed object XP fails to receive a label. The situation is different in the Japanese counterpart shown in (13).

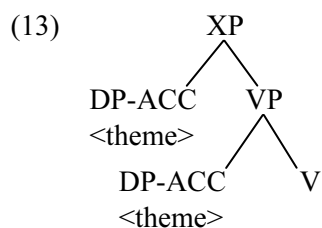

The two DP objects accompany suffixal accusative Case. Hence, by hypothesis, VP provides the label for XP, and there should be no problem with labeling. If the structure is illicit in Japanese, it suggests that the θ -criterion is indeed operative. On the other hand, if the structure is allowed, it raises doubts on the θ -criterion. In the following section, I build on the observations reported in Kuroda (1988) and argue that argument doubling of this kind is widely attested in Japanese.⁴

3. Argument Doubling as a General Phenomenon

Let us consider again the example of multiple nominative subjects in (5), repeated below in (14), before discussing examples of argument doubling.

- (14) [_{TP} Bunmeikoku-ga [_{TP} dansei-ga [_{TP} heikin-zyumyoo-ga
 civilized.country-NOM male-NOM average-life.span-NOM

⁴ The structure in (12) with two theme object DPs may be ruled out on yet independent grounds, e.g., for the failure of Case valuation. This complication does not arise with doubled PP arguments. A reviewer points out that the labeling algorithm allows a structure with two goal PPs, for example, if the higher PP is dislocated, say, with topicalization. This is a valid point and indicates that labeling with internal Merge, as illustrated in (2), is limited to A-A and A'-A' movements. This makes sense because in these cases, the internally merged phrase is interpreted as a single object that occurs in two positions. The situation is different when an argument internally merges in an A'-position. It is interpreted as a variable at the initial site and as an operator at the landing site.

mizika-i]]]

short-Pres.

‘It is in civilized countries that the male population has a short life-span.’

In this type of examples, the lowest nominative phrase is interpreted as the subject of the predicate. What is short is the average life span, and not civilized countries or their male population. The higher subjects are in some sort of predication relation with their sister TPs. Hence, examples of this kind are consistent with the θ -criterion.

The same point holds for multiple accusative sentences like (15), which have also been widely discussed in the literature since Harada (1973) and Kuroda (1978).

- (15) ?? Hanako-ga gakusei-o san-nin hamabe-o hasir-ase-ta
 Hanako-NOM student-ACC three-CL beach-ACC run-make-Past
 ‘Hanako made three students run on the beach.’

This example is marginal because there is a somewhat mysterious surface constraint in Japanese against multiple accusative phrases in a single clause. However, as Harada demonstrates, the example becomes perfect when one of the accusative phrases is dislocated. The cleft sentences in (16) illustrate this.

- (16) a. [_{CP} Hanako-ga gakusei-o san-nin hasir-ase-ta no]-wa
 Hanako-NOM student-ACC three-CL run-make-Past COMP-TOP
 hamabe-o da
 beach-ACC is
 ‘It is on the beach that Hanako made three students run.’
- b. [_{CP} Hanako-ga hamabe-o hasir-ase-ta no]-wa gakusei-o
 Hanako-NOM beach-ACC run-make-Past COMP-TOP student-ACC
 san-nin da
 three-CL is
 ‘It is three students that Hanako made run on the beach.’

The grammaticality of these examples indicates that multiple accusatives are allowed aside from the effects of the weak surface constraint. (15), like (14), is consistent with the θ -criterion because *gakusei-o* ‘student-ACC’ is the causee argument whereas *hamabe-o* ‘beach-ACC’ expresses a location or a path.

However, the situation is different with (17) from Kuroda (1988).

- (17) a. ?? Masao-ga Hanako-o hoho-o but-ta
 Masao-NOM Hanako-ACC cheek-ACC hit-Past
 ‘Masao hit Hanako on the cheek.’
- b. [_{CP} Masao-ga Hanako-o but-ta no]-wa hoho(-o) da
 Masao-NOM Hanako-ACC hit-Past COMP-TOP cheek-ACC is
 ‘It is on the cheek that Masao hit Hanako.’

Kuroda argues that the two accusative phrases in (17) receive the same θ -role from the verb. The example says that Masao hit Hanako, and more specifically, her cheek. Kuroda confirms this with the ungrammaticality of (18).

- (18) a. *Masao-ga Hanako-o yubi-o ni-hon ot-ta
 Masao-NOM Hanako-ACC finger-ACC two-CL break-Past
 ‘Masao broke two of Hanako’s fingers.’
- b. * [_{CP} Masao-ga Hanako-o ot-ta no]-wa yubi-o
 Masao-NOM Hanako-ACC break-Past COMP-TOP finger-ACC
 ni-hon da
 two-CL is
 ‘Lit. It is two fingers that Masao broke Hanako.’

This example is ungrammatical because one can break fingers but not a person, as (19) illustrates.⁵

⁵ Note that the contrast between (17a) and (18a) indicates that the former is not derived by possessor raising into a non-thematic position. If it were, the latter cannot be ruled out as (19a) is grammatical.

- (19) a. Masao-ga Hanako-no yubi-o ni-hon ot-ta
 Masao-NOM Hanako-GEN finger-ACC two-CL break-Past
 ‘Masao broke two of Hanako’s fingers.’
- b. *Masao-ga Hanako-o ot-ta
 Masao-NOM Hanako-ACC break-Past
 ‘Masao broke Hanako.’

Then, the verb *but* ‘hit’ in (17) assigns the theme role to both *Hanako* and *hoho* ‘cheek’ in violation of the θ -criterion.

Argument doubling of this kind, which Kuroda (1988) notes rather casually, is observed extensively in Japanese. He already presents an example similar to (17) with two dative arguments. It is shown in (20).

- (20) a. ?? Masao-ga Hanako-ni hoho-ni kisusi-ta
 Masao-NOM Hanako-DAT cheek-DAT kiss-Past
 ‘Masao kissed Hanako on the cheek.’
- b. [_{CP} Masao-ga Hanako-ni kisusi-ta no]-wa
 Masao-NOM Hanako-DAT kiss-Past COMP-TOP
 hoho-ni da
 cheek-DAT is
 ‘It is on the cheek that Masao kissed Hanako.’

In this example, *Hanako* and *hoho* ‘cheek’ are both thematic arguments of *kisusi* ‘kiss’. This can be confirmed with the following contrast:

- (21) a. [_{TP} Taroo-ga [_{TP} musume-ga totemo kasiko-i]]
 Taroo-NOM daughter-NOM very wise-Pres.
 ‘Taroo is such that his daughter is very wise.’
- b. *Masao-ga Taroo-ni musume-ni kisusi-ta
 Masao-NOM Taroo-DAT daughter-DAT kiss-Past
 ‘Lit. Masao kissed Taroo on his daughter.’

- c. *_{[CP} Masao-ga Taroo-ni kisusi-ta no]-wa musume-ni da
 Masao-NOM Taroo-DAT kiss-Past COMP-TOP daughter-DAT is
 ‘Lit. It is on his daughter that Masao kissed Taroo.’

(21a) is a typical example of the major subject construction. It says that Taroo is such that his daughter is wise, but does not imply that Taroo is wise. The discourse can continue with the utterance “But Taroo himself isn’t wise at all” without any contradiction. On the other hand, (21b, c) make sense only if kissing Taroo’s daughter automatically means kissing Taroo, which is not true.

Argument doubling is not limited to accusative and dative arguments. In (22), the PP expressing the source is doubled.

- (22) a. ?? Nihon-kara Hiroshima-kara(-dake) sankasya-ga at-ta
 Japan-from Hiroshima-from-only participant-NOM be-Past
 ‘Lit. There were participants only from Hiroshima from Japan.’
 b. _{[CP} Nihon-kara sankasya-ga at-ta no]-wa
 Japan-from participant-NOM be-Past COMP-TOP
 Hiroshima-kara(-dake) da
 Hiroshima-from-only is
 ‘Lit. It is (only) from Hiroshima that there were participants from Japan.’

(22b) is perfectly fine although there are two source PPs, *Nihon-kara* ‘from Japan’ and *Hiroshima-kara* ‘from Hiroshima’.⁶ The examples in (23) point to the same conclusion.

- (23) a. ?? Hanako-ga Yooroppa-e Doitu-e san-kai-dake it-ta
 Hanako-NOM Europe-to Germany-to three-CL-only go-Past
 ‘Lit. Hanako went only three times to Germany to Europe.’
 b. _{[CP} Hanako-ga Yooroppa-e it-ta no]-wa Doitu-e
 Hanako-NOM Europe-to go-Past COMP-TOP Germany-to

⁶ The degraded status of (23a) indicates that there is a constraint against multiple occurrences of a postposition in a simple sentence, similar to the ban on multiple accusative (and dative) phrases. I return to this in the following section.

san-kai(-dake) da
 three-CL-only is
 ‘Lit. It is (only) three times to Germany that Hanako went to Europe.’

In (23b), the goal argument is doubled, but the sentence is perfectly grammatical.

In addition, there is evidence that an external agent argument can also be doubled. Let us first consider the following examples with major subjects:

- (24) a. [TP Taroo-ga [TP musume-ga hito-ri(-dake) totemo kasiko-i]]
 Taroo-NOM daughter-NOM one-CL-only very wise-Pres.
 ‘Taroo is such that (only) one of his daughters is very wise.’
- b. ?? [TP Taroo-ga [TP musume-ga hito-ri(-dake) sono kaigi-de
 Taroo-NOM daughter-NOM one-CL-only that meeting-in
 hatugensi-ta]]
 speak.up-Past
 ‘Taroo is such that (only) one of his daughters spoke up in the meeting.’

As Kuno (1973) observes, the major subject construction is most natural with an individual-level predicate as the inner TP describes a property attributed to the major subject. Thus, (24b) is degraded compared with (24a). Further, a lower subject cannot be dislocated to a position above a higher subject in this construction. (25) is totally ungrammatical.

- (25) *[CP Taroo-ga totemo kasiko-i no]-wa musume-ga
 Taroo-NOM very wise-Pres. COMP-TOP daughter-NOM
 hito-ri(-dake) da
 one-CL-only is
 ‘Lit. It is (only) one of his daughters that Taroo is very wise.’ (cf. (24a))

Let us consider (26) with this background.

- (26) a. ?* Gakusei-ga itinensei-ga san-nin(-dake) sono kaigi-de
 student-NOM freshman-NOM three-CL-only that meeting-in
 hatugensi-ta
 speak.up-Past
 ‘Lit. The students are such that (only) three freshmen spoke up in the
 meeting.’
- b. [_{CP} Gakusei-ga sono kaigi-de hatugensi-ta no]-wa
 student-NOM that meeting-in speak.up-Past COMP-TOP
 itinensei-ga san-nin(-dake) da
 freshman-NOM three-CL-only is
 ‘Lit. It is (only) three freshmen that students spoke up in the meeting.’

(26a) is degraded. When interpretation is forced, it sounds like a major subject sentence with a wrong kind of predicate. On the other hand, (26b) is fine. This cleft example cannot be derived from a major subject sentence by placing *itinensei-ga san-nin(-dake)* ‘freshman-NOM three-CL(-only)’ in the focus position. (25) shows that it would result in complete ungrammaticality. Then, why is (26b) grammatical?

There is one outstanding difference between (24a) and (26a). The former does not say that Taroo is smart, as mentioned. On the other hand, (26a) implies that students spoke up in the meeting. Thus, (26a) need not be a regular major subject sentence but can be an instance of thematic subject doubling. The example is degraded even under this reading because it is a simple sentence containing two thematic nominative arguments. But this surface effect is avoided when one of the nominative arguments is displaced as in (26b). If this analysis is correct, then (26b) shows that an agentive subject can also be doubled in Japanese.

In this section, I argued, building on Kuroda’s (1988) lead, that any thematic argument can be doubled in Japanese. This demonstrates that the θ -criterion should be eliminated as a verb can assign the same θ -role to more than one argument quite generally. One question that remains is why (24a), for example, cannot be construed as an example of thematic subject doubling. If it could be, (25) should be grammatical. I simply stated above that the example does not convey that Taroo is very smart, and hence, must be an instance of the major subject construction. But the fact indicates that there is a

restriction on argument doubling that forces the major subject interpretation of (24a). I turn to this in the following section.

4. Argument Doubling as a Focus Construction

The following simple examples show that argument doubling is not quite free:

- (27) a. *Hanako-ga Taroo-o gakusei-o san-nin sikat-ta
 Hanako-NOM Taroo-ACC student-ACC three-CL scold-Past
 ‘Intended. Hanako scolded Taroo and three students.’
- b. *[_{CP} Hanako-ga Taroo-o sikat-ta no]-wa gakusei-o
 Hanako-NOM Taroo-ACC scold-Past COMP-TOP student-ACC
 san-nin da
 three-CL is
 ‘Lit. It is three students that Hanako scolded Taroo.’

Then, what makes the grammatical examples of argument doubling possible? I consider this question in this section.

Kuroda’s (1988) examples in (17b) and (20b), repeated below as (28a) and (28b), suggest that the doubled arguments should have a whole-part relation with body parts.

- (28) a. [_{CP} Masao-ga Hanako-o but-ta no]-wa hoho(-o) da
 Masao-NOM Hanako-ACC hit-Past COMP-TOP cheek-ACC is
 ‘It is on the cheek that Masao hit Hanako.’
- b. [_{CP} Masao-ga Hanako-ni kisu-ta no]-wa hoho-ni da
 Masao-NOM Hanako-DAT kiss-Past COMP-TOP cheek-DAT is
 ‘It is on the cheek that Masao kissed Hanako.’

However, the other examples discussed above show that the requirement is not so specific. (22b), repeated below as (29), has nothing to do with body parts.

- (29) [_{CP} Nihon-kara sankasya-ga at-ta no]-wa
 Japan-from participant-NOM be-Past COMP-TOP
 Hirosima-kara(-dake) da
 Hiroshima-from-only is
 ‘Lit. It is (only) from Hiroshima that there were participants from Japan.’

Another relevant example is shown in (30).

- (30) a. ?* Hanako-ga kudamono-o ringo-o hito-tu tabe-ta
 Hanako-NOM fruit-ACC apple-ACC one-CL eat-Past
 ‘Hanako ate fruits, and it was an apple.’
 b. [_{CP} Hanako-ga kudamono-o tabe-ta no]-wa ringo-o
 Hanako-NOM fruit-ACC eat-Past COMP-TOP apple-ACC
 hito-tu(-dake) da
 one-CL-only is
 ‘Lit. It is only one apple that Hanako ate fruits.’

Let us first look into the properties of (30) to see what sort of relation is required between the two accusative theme objects. First, the example clearly implies that Hanako ate a fruit and that Hanako ate an apple. This is expected if the two accusative arguments both receive the theme role from the verb *tabe* ‘eat’ as Kuroda observed. Furthermore, Hanako eating a fruit and her eating an apple is the same event. It seems then that for (31a) to be legitimate, (31b) must hold.

- (31) a. [_{TP} ... DP-ACC₁ DP-ACC₂ ...]
 b. [_{TP} ... DP-ACC₁ ...] and [_{TP} ... DP-ACC₂ ...] depict the same event/state.

This distinguishes the grammatical cases from (27). In the latter, Hanako scolding Taroo and her scolding three students cannot be considered the same event even if Taroo is one of the three students.

Secondly, (30a) improves as focus is placed on the second accusative argument. (32)

with the focus particle *-dake* ‘only’ on this argument is already better than (30a).

- (32) ? Hanako-ga kudamono-o ringo-o hito-tu-dake tabe-ta
 Hanako-NOM fruit-ACC apple-ACC one-CL-only eat-Past
 ‘Hanako ate fruits, and what she ate was only one apple.’

And when the argument is placed in the focus position of a cleft sentence, the example becomes perfect as (30b) shows.

A similar effect can be achieved by making the first argument a topic. Thus, (33b) is far better than (33a).⁷

- (33) a. ?* Hanako-ga Yooroppa-e Doitu-e san-kai it-ta
 Hanako-NOM Europe-to Germany-to three-CL go-Past
 ‘Lit. Hanako went to Germany three times to Europe.’
 b. ? Yooroppa-e-wa Hanako-ga Doitu-e san-kai it-ta
 Europe-to-TOP Hanako-NOM Germany-to three-CL go-Past
 ‘Lit. To Europe, Hanako went to Germany three times.’

Then, argument doubling seems to require that the second argument be a focus. This descriptive conclusion is confirmed further by the fact that the first argument cannot be placed in focus. (34a) is totally ungrammatical in clear contrast to (23b), repeated in (34b).

- (34) a. *[_{CP} Hanako-ga Doitu-e san-kai(-dake) it-ta no]-wa
 Hanako-NOM Germany-to three-CL-only go-Past COMP-TOP
 Yooroppa-e da
 Europe-to is
 ‘Lit. It is to Europe that Hanako went (only) three times to Germany.’

⁷ An example of PP doubling is employed here because a DP topic may be licensed by the “aboutness” relation as Kuno (1973) demonstrates and hence it is not clear that it participates in argument doubling.

- b. [_{CP} Hanako-ga Yooroppa-e it-ta no]-wa Doitu-e
 Hanako-NOM Europe-to go-Past COMP-TOP Germany-to
 san-kai(-dake) da
 three-CL-only is
 ‘Lit. It is (only) three times to Germany that Hanako went to Europe.’

Given this, I suggest in the remainder of this section that the first argument in argument doubling must serve to specify the set of alternatives for the focus, in the sense of Rooth (1992). Rooth proposes that a focus generates a set of alternatives. Let us consider (35) for an illustration.

- (35) a. John saw MARY.
 b. {Bill, Susan, Mary, ...}
 c. {John saw Bill, John saw Susan, John saw Mary, ...}

Focus is placed on *Mary* in (35a). (35b) is the set of alternatives for *Mary*, that is, the set of people that John could see. Then, roughly speaking, (35a) asserts that ‘John saw Mary’ is the true sentence among those in the set (35c). Consequently, it is interpreted as ‘It is Mary that John saw’. Rooth assumes that the set of alternatives that a focus generates is determined by the context.

This analysis of focus provides an insight into the interpretation of (30b), repeated in (36a).

- (36) a. [_{CP} Hanako-ga kudamono-o tabe-ta no]-wa ringo-o
 Hanako-NOM fruit-ACC eat-Past COMP-TOP apple-ACC
 hito-tu(-dake) da
 one-CL-only is
 ‘Lit. It is only one apple that Hanako ate fruits.’
- b. [_{CP} Hanako-ga tabe-ta no]-wa ringo-o hito-tu(-dake) da
 Hanako-NOM eat-Past COMP-TOP apple-ACC one-CL-only is
 ‘It is only one apple that Hanako ate.’

This example states that an apple is the only fruit that Hanako ate. In particular, it does not mean that an apple is the only thing that Hanako ate. She could have eaten some vegetables and meat in addition. The interpretation absent with (36a) obtains when the first accusative argument *kudamono-o* ‘fruit-ACC’ is missing as in (36b). Then, this accusative argument serves in (36a) to restrict the set of alternatives to fruits as in (37).

(37) {one orange, two bananas, five peaches, one banana, one apple, ...}

(36a) indeed means that it is only *one apple* among the members of the set in (37) that Hanako ate.

Recall that *kudamono-o* ‘fruit-ACC’ in (36a) is interpreted as a theme. So, the sentence implies (38).

(38) Hanako-ga kudamono-o tabe-ta
 Hanako-NOM fruit-ACC eat-Past
 ‘Hanako ate fruits.’

At the same time, this accusative argument specifies the set of alternatives for the second accusative object. Then, it is only natural that it is indefinite. If it were ‘all fruits’, for example, it could still specify the set of alternatives, but would lead to a contradiction because the sentence implies that Hanako ate all fruits, not just an apple.

This analysis is still at an informal stage, but extends to the other examples discussed so far. Let us consider again Kuroda’s (28b), repeated in (39).

(39) [_{CP} Masao-ga Hanako-ni kisusi-ta no]-wa hoho-ni da
 Masao-NOM Hanako-DAT kiss-Past COMP-TOP cheek-DAT is
 ‘It is on the cheek that Masao kissed Hanako.’

Hanako here can be construed as ‘Hanako’s body parts’. Then, it specifies the set of alternatives in (40).

(40) {Hanako's hand, Hanako's head, Hanako's cheek, ...}

The example states that it is *Hanako's cheek* among the members of the set in (40) that Masao kissed. The ungrammaticality of (27b), repeated below as (41), is also expected under the analysis.

(41) *_{[CP} Hanako-ga Taroo-o sikat-ta no]-wa gakusei-o
 Hanako-NOM Taroo-ACC scold-Past COMP-TOP student-ACC
 san-nin da
 three-CL is
 'Lit. It is three students that Hanako scolded Taroo.'

Taroo-o 'Taroo-ACC' simply fails to specify the set of alternatives for *gakusei-o san-nin* 'three students'.

I suggested in this section that in argument doubling, the second argument must be a focus and the first must serve to specify its set of alternatives. This provides a partial answer for why the good examples of argument doubling involve dislocation of one of them. The dislocation must help establish the required relation between the two arguments by putting the second in focus or making the first the topic. Before I close this section, I would like to briefly speculate on why this specific relation obtains between doubled arguments.

The main conclusion of Section 3 was that a verb can assign a single θ -role to two arguments. This implies that an argument need not have a unique role in the predicate argument structure. When it is interpreted as the theme, for example, there may be another theme argument in the sentence. However, the informal analysis in this section suggests that each argument must have a unique role in the wider semantic interpretation. In (39), *hoho-ni* 'cheek-DAT' shares the θ -role with *Hanako-ni*, but is unique as a focus. *Hanako-ni*, on the other hand, has the unique role of specifying the set of alternatives for the focus. Although this is merely a speculation at this point, a version of the θ -criterion that is generalized beyond thematic roles may be at work as part of Full Interpretation.

5. Conclusion

In this paper, I first noted that typical examples of θ -criterion violations in English receive an independent account as cases of failure in labeling. Then, I pointed out that the labeling mechanism for Japanese I proposed in Saito (2014) allows argument doubling in the language. This implies that if argument doubling is indeed permitted in Japanese, it constitutes evidence that the θ -criterion should be dispensed with. Given this, I examined argument doubling in Japanese, extending Kuroda's (1988) observations. I argued that the phenomenon obtains quite generally and provides solid evidence against the θ -criterion. At the same time, I arrived at the conclusion that argument doubling requires one of the arguments to be a focus and the other to specify the set of alternatives for the focus. I speculated at the end that although the θ -criterion seems untenable, there may be a more general requirement that each argument play a unique role in semantic interpretation.

(Proofreader: Li Qi-hong)

References

- Chomsky, Noam. "Problems of Projection," *Lingua*, 130, 2013, pp. 33-49. doi: 10.1016/j.lingua.2012.12.003
- Harada Shin-ichi. "Counter Equi NP Deletion," *Annual Bulletin of Research Laboratory of Logopedics and Phoniatics*, 7, 1973, pp. 113-147.
- Heycock, Caroline. "Japanese -wa, -ga and Information Structure," in Miyagawa Shigeru and Saito Mamoru (eds.), *The Oxford Handbook of Japanese Linguistics*. New York: Oxford University Press, 2008, pp. 54-83. doi: 10.1093/oxfordhb/9780195307344.013.0003
- Kuno Susumu. *The Structure of the Japanese Language*. Cambridge, Mass.: MIT Press, 1973.
- Kuroda S.-Y. "Case-marking, Canonical Sentence Patterns and Counter Equi in Japanese," in John Hinds and Irwin Howard (eds.), *Problems in Japanese Syntax and Semantics*. Tokyo: Kaitakusha, 1978, pp. 30-51.
- _____. "Whether We Agree or Not: A Comparative Syntax of English and Japanese," *Linguisticae Investigationes*, 12, 1988, pp. 1-47. doi: 10.1075/li.12.1.02kur
- Rooth, Mats. "A Theory of Focus Interpretation," *Natural Language Semantics*, 1, 1992, pp. 75-116. doi: 10.1007/BF02342617
- Saito Mamoru. "Scrambling as Semantically Vacuous A'-movement," in Mark R. Baltin and Anthony S. Kroch (eds.), *Alternative Conceptions of Phrase Structure*. Chicago: University of Chicago Press, 1989, pp. 182-200.
- _____. "A Derivational Approach to the Interpretation of Scrambling Chains," *Lingua*, 113, 2003, pp. 481-518. doi: 10.1016/S0024-3841(02)00083-9
- _____. "Case and Labeling in a Language without ϕ -feature Agreement," in Anna Cardinaletti, Guglielmo Cinque and Endo Yoshio (eds.), *On Peripheries: Exploring Clause Initial and Clause Final Positions*. Tokyo: Hituzi Syobo Publishing, 2014, pp. 269-297.
- Webelhuth, Gert. "Syntactic Saturation Phenomena and the Modern Germanic Languages," Ph.D. Dissertation, Amherst: University of Massachusetts, 1989.

詞組標籤理論和日語論元重複現象

齋藤衛

南山大學言語學研究中心

saito@nanzan-u.ac.jp

摘 要

本文以 Chomsky (2013) 的詞組標籤運算 (labeling algorithm) 為基準，探討論旨準則 (θ -criterion) 在當代句法理論中的必要性。本文從英語出發，指出句法理論中詞組標記系統與論旨準則的功能有所重疊；經由討論日語論元重複 (argument doubling) 結構，我們發現論旨準則在語料實證上確有不足。這顯示論旨準則應從當代句法理論中剔除，由標籤運算取代其功能。

關鍵詞：論元重複，自由合併，詞組標籤，論旨準則，焦點，另類選項集合

(收稿日期：2016. 3. 8；修正稿日期：2016. 8. 31；通過刊登日期：2016. 12. 15)

